

# Ball Stud Mount

C-728 and C-729 are fabricated to mount the C-690 air struts. When installed, access to the #8 nuts is very limited. The only way torque can be applied to the screw is to the Philips screw heads. With limited torque, these mounts will work loose given the leverage of the tip up canopy mount.



We have addressed this with the 7-0300-0 Ball stud mount kit.

The 7-0300-0 kit consists of:

2ea ball stud mounts, 2 nut assemblies, 4ea 1032 x 5/8 stainless socket head cap screws.



Tools required are a 5/32 Allen wrench (T handle preferred)

9/16 open end wrench

½" open end wrench

#2 Philips screwdriver and 11/32 box end wrench for removing existing parts.



We start with a billet knob mount. This beauty is anodized for looks and protection. One of the biggest advantages is the nut assemblies. They are linked together so that no tools are required in the limited space behind the canopy deck. The dip in the middle of the nut assembly allows room for a fingertip to push the flat side of the nut up to the aircraft structure.

We have increased the screw size from 832 to 1032, so the mount holes in the canopy deck will need to be enlarged to #11 (.191" drill). A 5/32 Allen wrench is required for the socket head cap screws. A T handle Allen wrench is preferred.

To install:



If your canopy rail has not yet been drilled, consider drilling the holes in the rail a bit lower than Van's instructions. Drilling per Van's, puts the top edge of the mount above the edge of the canopy deck. It will look nicer lowering the mount holes. You do however have to make sure the gas cylinder has adequate clearance to the canopy deck.

Tie the canopy in the open position by tying one end to the canopy handle and the other around the prop. If you have a helper, they can hold the canopy open for you. You will need to remove the existing mounts, and one cylinder assembly (c-690) will not support the canopy.

**Remove one side, leaving the canopy supported by the rope and other strut.**

**Drill out the mount holes as detailed above. Use the new knob mount to verify the holes are lined up. Place one of the screws on to the end of your Allen wrench. Run it through one of the mount holes.**

**Work one of the nut assemblies behind the channel and align with the mount holes. The Flat part of the nut assembly goes against the channel.**

**Start the screw that you placed on the end of the Allen wrench.**

**Looking through the mount holes, align the nut with the remaining mount hole. Thread the other screw in to place.**

**If you have a torque wrench, torque to 40 inch pounds.**

**Reinstall the strut through the 5/16 hole in the mount.**

**Repeat on the other side.**

**Enjoy your Ball stud mount.**

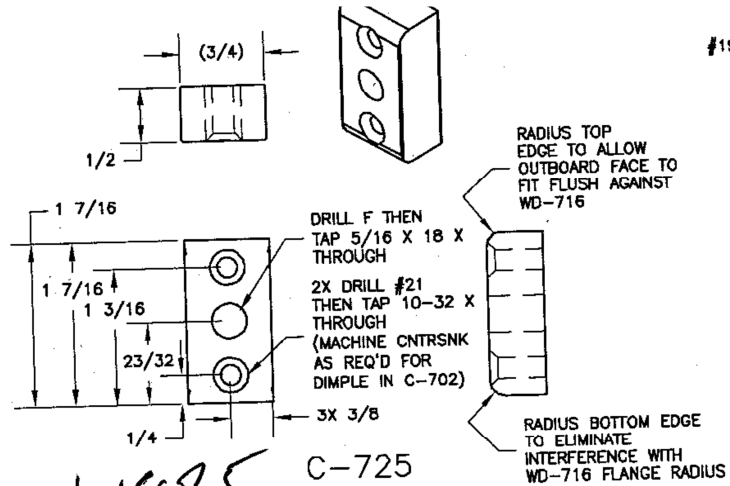

1.1875  
 0.7187  
 250  
 C-725  
 BALL STUD FWD MOUNT  
 FULL SCALE, 2 REQ'D  
 MAKE FROM: AB3-1 1/2X3/4

