

PennEngineering®

**BULLETIN**



**FE™**

**MINIATURE SELF-CLINCHING  
FASTENERS**





# MINIATURE SELF-CLINCHING FASTENERS

**PEM® brand miniature fasteners fit into a minimal space and provide strong, reusable threads.**

PEM miniature fasteners provide immediate visual indication when proper installation has been accomplished.

A strong, knurled collar, which is embedded in the sheet, guarantees against rotation of the fastener in the sheet. The torque-out resistance of the knurl greatly exceeds the torque that can be exerted by the self-locking feature.

When this collar is embedded in the sheet, the undercut cavity beneath the collar is filled with displaced sheet material thereby developing pushout resistance.

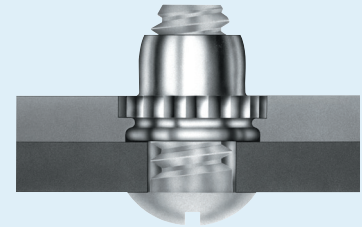

FE/FEO/UL prevailing torque locknuts provide ideal solutions to prevent mating hardware from loosening in service due to vibration or other application-related factors. A design feature of the lock nut produces friction between threads of mated components thereby increasing the force needed to tighten as well as loosen the nut. Prevailing torque locknuts provide essentially the same torque value regardless of the amount of axial load applied. Their use can save time and money compared with alternative chemical locking methods or patches.

A dry-film lubricant applied to locking FE/FEO/UL nuts provides the smooth, non-galling prevailing torque performance necessary for reliable locking and for reusability.<sup>(1)</sup> Screws for use with PEM self-clinching locking fasteners should be Class 3A/4h fit or no smaller than Class 2A/6g.

<p><b>FE™/FEO™/UL™</b> elliptically squeezed nuts are <b>self-locking</b>. FE/FEO nut thread locking torque performance is equivalent to applicable NASM25027 specifications. UL self-locking nuts meet locking torque requirements specified herein. Some sizes of FE/FEO/UL nuts can be ordered to NASM45938/7 specifications <sup>(2)</sup>. For more information on NASM25027 as applied to PEM self-clinching, self-locking nuts, check our web site for tech sheet PEM® - Ref/NASM25027.</p>	
<p><b>FEX™/FEOX™/U™</b> nuts have <b>free-running</b> class 2B/6H strong reusable threads. These fasteners can be installed into thinner sheets and closer to the edge of a sheet than standard self-clinching nuts. Some sizes of FEX/FEOX/U nuts can be ordered to NASM45938/7 specifications <sup>(2)</sup>.</p>	

- (1) Consult Bulletin LN for complete line of self-clinching, locking fasteners.
- (2) To meet national aerospace standards and to obtain testing documentation, product must be ordered using appropriate NASM45938/7 part number. Check our web site for a complete Military Specification and National Aerospace Standards Reference Guide (Bulletin NASM).

## PART NUMBER DESIGNATION

<b>U</b>	-	<b>080</b>	-	<b>0</b>	
<b>UL</b>	-	<b>080</b>	-	<b>0</b>	<b>CW</b>
<b>FE</b>	-	<b>440</b>	-		<b>MD</b>
<b>FEX</b>	-	<b>440</b>			
<b>FEO</b>	-	<b>440</b>	-		<b>MD</b>
<b>FEOX</b>	-	<b>440</b>			
↓		↓		↓	↓
Type		Thread Code		Shank Code	Finish Code



# MINIATURE SELF-CLINCHING FASTENERS

## SPECIFICATIONS

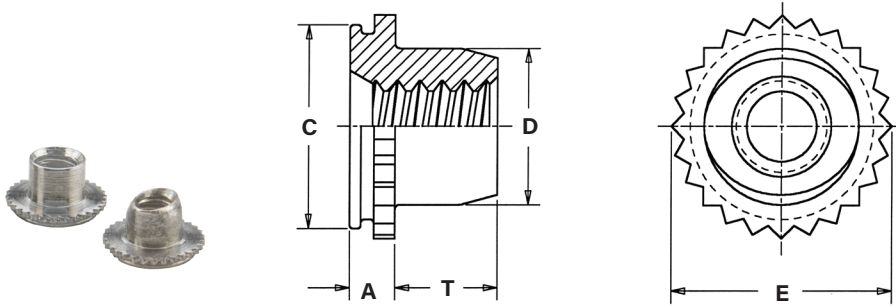

U/FEX/FEQX NUTS ARE ROUND

TOPS OF UL/FE/FEQ NUTS HAVE ELLIPTICALLY SQUEEZED LOCKING FEATURE

Clinching profile may vary.

All dimensions are in inches.

	Thread Size	Type		Thread Code	Shank Code (2)	A (Shank) Max.	Sheet Thickness (3)	Hole Size In Sheet +.003 - .000	C +.000 - .005	D Max.	E ±.005	T +.015 - .000	Min. Dist. Hole To Edge	Max. Hole In Attached Parts
		Non-locking(1)	Self-locking											
UNIFIED	.060-80 (#0-80)	U	UL	080	0	.020	.019-.022	.110	.1095	.076	.125	.050	.09	.080
	.073-64 (#1-64)	U	UL	164	0	.020	.019-.022	.110	.1095	.090	.125	.050	.09	.093
	.086-56 (#2-56)	U	UL	256	0	.020	.019-.022	.144	.1435	.106	.160	.065	.11	.106
					1	.031	.030-.036							
	.112-40 (#4-40)	FEQX	FEO	440		.040	.039-.045	.172	.171	.145	.192	.065	.14	.132
		FEX	FE			.060	.059-.070							
	.138-32 (#6-32)	FEQX	FEO	632		.040	.039-.045	.213	.212	.180	.244	.075	.17	.158
		FEX	FE			.060	.059-.070							
	.164-32 (#8-32)	FEQX	FEO	832		.040	.039-.045	.290	.289	.215	.322	.090	.20	.184
		FEX	FE			.060	.059-.070							
	.190-32 (#10-32)	FEQX	FEO	032		.040	.039-.045	.290	.289	.245	.322	.110	.20	.210
		FEX	FE			.060	.059-.070							
	1/4-20	FEX	FE	0420		.060	.059-.070	.344	.343	.318	.384	.120	.28	.270
	1/4-28			0428										

All dimensions are in millimeters.

	Thread Size x Pitch	Type		Thread Code	Shank Code (2)	A (Shank) Max.	Sheet Thickness (3)	Hole Size In Sheet +0.08	C -0.13	D Max.	E ±0.13	T +0.4	Min. Dist. Hole To Edge	Max. Hole In Attached Parts
		Non-locking(4)	Self-locking											
METRIC	M2 x 0.4	U	UL	M2	1	0.79	0.76-0.91	3.61	3.6	2.5	4.07	1.65	2.8	2.5
	M3 x 0.5	FEQX	FEO	M3		1.02	0.99-1.14	4.39	4.37	3.96	4.88	1.9	3.6	3.5
		FEX	FE			1.53	1.5-1.78							
	M4 x 0.7	FEQX	FEO	M4		1.02	0.99-1.14	7.39	7.37	5.23	8.17	2.55	5.2	4.5
		FEX	FE			1.53	1.5-1.78							
	M5 x 0.8	FEQX	FEO	M5		1.02	0.99-1.14	7.39	7.37	6.48	8.17	3.05	5.2	5.5
		FEX	FE			1.53	1.5-1.78							
	M6 x 1	FEX	FE	M6		1.53	1.5-1.78	8.74	8.72	7.72	9.74	3.3	7.1	6.5

- (1) 2B Go Gauge may stop at barrel end but class 3A screw will pass thru with finger torque.
- (2) Shank code applicable only to U and UL fasteners.
- (3) In applications between the sheet thicknesses for your thread size, see last paragraph of installation data on page 4. Knurled collar may fracture if fastener is used in sheets thicker than the specified range and the screw is tightened beyond maximum tightening torque.
- (4) 6H Go Gauge may stop at barrel end but class 4h screw will pass thru with finger torque.



# MINIATURE SELF-CLINCHING FASTENERS

## MATERIAL AND FINISH SPECIFICATIONS

Type	Threads		Fastener Material	Standard Finishes			For Use In Sheet Hardness <sup>(1)</sup>	Locking Temperature Limit	Self-locking	Covered by M45938/7 <sup>(2)</sup>
	Internal, ASME B1.1, 2B / ASME B1.13M, 6H	Internal, UNJ Class 3B per ASME B1.15 / MJ Class 4H6H per ASME B1.21M (M6 thread 4H5H)		Passivated and/or Tested Per ASTM A380	Passivated Plus Clear Dry-film Lubricant	Black Dry-film Lubricant				
U	▪		▪	▪						
UL		▪	▪		▪		400° F / 204° C	▪	▪	
FE		▪	▪		▪		400° F / 204° C	▪	▪	
FEX	▪		▪	▪						
FEO		▪	▪		▪		400° F / 204° C	▪	▪	
FE0X	▪		▪	▪						
Part number codes for finishes				None	CW <sup>(3)</sup>	MD <sup>(4)</sup>				

(1) HRB - Hardness Rockwell "B" Scale. HB - Hardness Brinell.

(2) To meet national aerospace standards and to obtain testing documentation, product must be ordered using appropriate NASM45938 part number.

Check our web site for a complete Military Specification and National Aerospace Standards Reference Guide (Bulletin NASM).

(3) See PEM Technical Support section of our web site for related plating standards and specifications.

(4) MD finish on stainless steel provides a minimum of 100 hours of salt spray resistance.

## INSTALLATION

1. Prepare properly sized mounting hole in sheet. Do not perform any secondary operations such as deburring.
2. Insert fastener into the anvil hole and place the mounting hole (preferably the punch side) over the shank of the fastener as shown in the drawing.
3. With installation punch and anvil surfaces parallel, apply squeezing force to the knurled collar until knurled collar is flush with top of the sheet for sheets .060"/1.5mm thick and up, or until shank is flush with the bottom of the sheet for sheets .040"/1mm to .060"/1.5mm thick for FE/FEO nuts.

PEM miniature fasteners must be installed by a force applied through parallel surfaces. Since force must not be applied to the barrel, a cavity must be used in either the punch or anvil so that the installation force is applied to the knurled collar. "D" dimensions for the punch or anvil cavity are given in the tables on page 3.

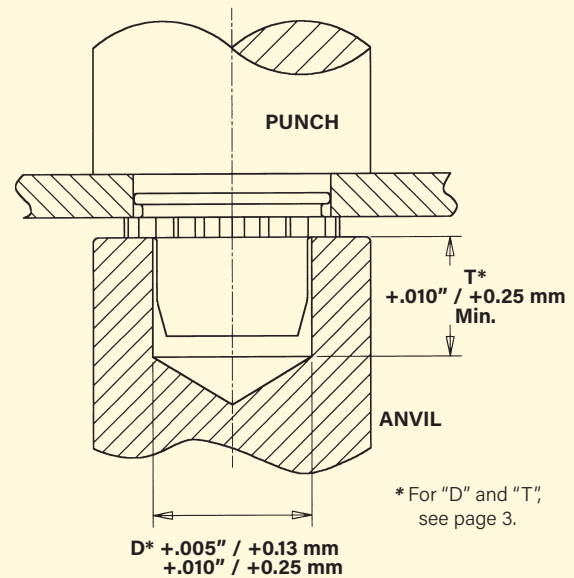

## PEMSERTER® Installation Tooling

Type	Thread	Anvil Part Number	Punch Part Number
U/UL	080	8008451	975200048
U/UL	164	970200300300	
U/UL	256/M2	975200020	
FE/FEO/FEX/FE0X	440/M3	975200021	
FE/FEO/FEX/FE0X	632	975200022	
FE/FEO/FEX/FE0X	832/M4	975200023	
FE/FEO/FEX/FE0X	032/M5	975200024	
FE/FEO/FEX/FE0X	0420	975200025	
FE/FEO/FEX/FE0X	M6	8013143	

### INSTALLATION NOTES

- For best results we recommend using a PEMSERTER® press for installation of PEM self-clinching fasteners. Please check our website for more information.
- Visit the Animation Library on our website to view the installation process [for this product](#).

## INSTALLATION RECOMMENDATION

In applications for sheet thicknesses between the two ranges (see "Sheet Thickness" on page 3) use the fastener with the larger "A" dimension. For example, if you want a #4-40 thread and your sheet thickness is between .045"/1.14 mm and .059"/1.49 mm, you should use FE or FEX nuts. This is not recommended installation practice, but in this case if it is necessary, you should install the fastener so that the bottom of the shank is flush with the underside of the sheet (instead of having the top of the knurled collar flush with the top of the sheet). When this method is used, care must be taken to protect the fastener against crushing which would damage the threads. This method will also result in reduced pushout and torque-out values.



# MINIATURE SELF-CLINCHING FASTENERS

## PERFORMANCE DATA FOR TYPES U/UL<sup>(1)</sup>

UNIFIED	Type	Thread Code	Shank Code	Test Sheet Material					
				5052-H34 Aluminum			Cold-rolled Steel		
				Installation (lbs.)	Pushout (lbs.)	Torque-out (in. lbs.)	Installation (lbs.)	Pushout (lbs.)	Torque-out (in. lbs.)
U/UL	080	0	750	20	2	1000	30	2	
	164	0	750	20	3	1000	30	3	
	256	0	1000	20	4	1300	30	4	
1									

METRIC	Type	Thread Code	Shank Code	Test Sheet Material					
				5052-H34 Aluminum			Cold-rolled Steel		
				Installation (kN)	Pushout (N)	Torque-out (N-m)	Installation (kN)	Pushout (N)	Torque-out (N-m)
U/UL	M2	1	4	89	0.45	5.8	133	0.45	

## PERFORMANCE DATA FOR TYPES FE/FE0/FEX/FE0X<sup>(1)(2)</sup>

UNIFIED	Type	Thread Code	Test Sheet Material					
			5052-H34 Aluminum			Cold-rolled Steel		
			Installation (lbs.)	Pushout (lbs.)	Torque-out (in. lbs.)	Installation (lbs.)	Pushout (lbs.)	Torque-out (in. lbs.)
UNIFIED	FE0/FE0X	440	900	88	12	1500	140	12
	FE/FEX			135			210	
	FE0/FE0X	632	1200	105	20	2100	185	20
	FE/FEX		1300	175			255	
	FE0/FE0X	832	1500	155	48	2500	260	48
	FE/FEX			255			360	
	FE0/FE0X	032	1500	155	48	2500	260	48
	FE/FEX			255			360	
	FE/FEX	0420	2100	320	110	3500	420	110
		0428						

METRIC	Type	Thread Code	Test Sheet Material					
			5052-H34 Aluminum			Cold-rolled Steel		
			Installation (kN)	Pushout (N)	Torque-out (N-m)	Installation (kN)	Pushout (N)	Torque-out (N-m)
METRIC	FE0/FE0X	M3	4	391	1.35	6.7	622	1.35
	FE/FEX			600			934	
	FE0/FE0X	M4	6.7	689	5.42	11.1	1156	5.42
	FE/FEX			1134			1601	
	FE0/FE0X	M5	6.7	689	5.42	11.1	1156	5.42
	FE/FEX			1134			1601	
	FE/FEX	M6	9.4	1423	12.43	15.6	1868	12.43

(1) Published installation forces are for general reference. Actual set-up and confirmation of complete installation should be made by observing proper seating of fastener as described in the installation steps. Other performance values reported are averages when all proper installation parameters and procedures are followed. Variations in mounting hole size, sheet material, and installation procedure may affect performance. Performance testing this product in your application is recommended. We will be happy to provide technical assistance and/or samples for this purpose.

(2) For FE and FEO fasteners, thread locking performance is equivalent to applicable NASM25027 specifications. Consult technical sheet PEM-REF/NASM25027 on our web site for details.

# MINIATURE SELF-CLINCHING FASTENERS

## AXIAL STRENGTH AND TIGHTENING TORQUE COMPARISON

UNIFIED	Thread Code	Increasing Axial Strength →					
		U-0/UL-0/FE0X/FE0 Nuts			U-1/UL-1/FE/FE Nuts		
		Locknut Min. Axial Strength (lbs.) <sup>(1)</sup>	Mating Screw		Locknut Min. Axial Strength (lbs.) <sup>(1)</sup>	Mating Screw	
	Strength Level (ksi) <sup>(2)</sup>	Tightening Torque (in. lbs.) <sup>(3)</sup>		Strength Level (ksi) <sup>(2)</sup>	Tightening Torque (in. lbs.) <sup>(3)</sup>		
080	125	69	1.0	—	—	—	
164	125	49	1.2	—	—	—	
256	169	46	1.9	316	85	3.5	
440	465	77	6.8	705	117	10.3	
632	546	60	9.8	847	93	15.2	
832	779	56	16.6	1,213	87	25.9	
032	779	39	19.2	1,213	61	30.0	
0420	—	—	—	1,412	44	45.9	

METRIC	Thread Code	Increasing Axial Strength →					
		U-0/UL-0/FE0X/FE0 Nuts			U-1/UL-1/FE/FE Nuts		
		Locknut Min. Axial Strength (kN) <sup>(1)</sup>	Mating Screw		Locknut Min. Axial Strength (kN) <sup>(1)</sup>	Mating Screw	
	Strength Level (MPa) <sup>(2)</sup>	Tightening Torque (N-m) <sup>(3)</sup>		Strength Level (MPa) <sup>(2)</sup>	Tightening Torque (N-m) <sup>(3)</sup>		
M2	—	—	—	1.39	432	0.36	
M3	2.08	267	0.81	3.16	405	1.23	
M4	3.48	255	1.81	5.42	398	2.82	
M5	3.48	158	2.26	5.42	246	3.52	
M6	—	—	—	6.28	201	4.9	

(1) Axial strength for nuts is limited by knurled ring strength.

(2) Screw strength level shown is the minimum needed to develop full nut strength, higher strength screws may be used.

(3) Tightening torque shown will induce preload of 65% of locknut minimum axial strength with K or nut factor is equal to 0.20. In some applications tightening torque may need to be adjusted based on the actual K value. If screw strength is less than the value shown, tightening torque should be proportionately reduced by multiplying the torque shown by the actual screw strength over the screw strength shown. If higher strength screws are used, torque is not adjusted upward because assemble strength is still limited by locknut strength.



Fastener drawings and models are available at [www.pemnet.com](http://www.pemnet.com)

All PEM® products meet our stringent quality standards. If you require additional industry or other specific quality certifications, special procedures and/or part numbers are required. Please contact your local sales office or representative for further information.

Regulatory compliance information is available in Technical Support section of our website. Specifications subject to change without notice. See our website for the most current version of this bulletin.

**PennEngineering®**



**North America:** Danboro, PA USA • E-mail: [info@pemnet.com](mailto:info@pemnet.com) • Tel: +1-215-766-8853 • Fax: +1-215-766-0143 • 800-237-4736 (USA Only)  
**Europe:** Galway, Ireland • E-mail: [europe@pemnet.com](mailto:europe@pemnet.com) • Tel: +353-91-751714 • Fax: +353-91-753541  
**Asia/Pacific:** Singapore • E-mail: [singapore@pemnet.com](mailto:singapore@pemnet.com) • Tel: +65-6-745-0660 • Fax: +65-6-745-2400  
 Shanghai, China • E-mail: [china@pemnet.com](mailto:china@pemnet.com) • Tel: +86-21-5868-3688 • Fax: +86-21-5868-3988

Visit our PEMNET™ Resource Center at [www.pemnet.com](http://www.pemnet.com)

Technical support e-mail: [techsupport@pemnet.com](mailto:techsupport@pemnet.com)

© 2017 PennEngineering.